

ABSOLUTE MAXIMUM RATINGS

Item	Symbol	Min.	Max.	Unit
Supply Voltage(Logic)	$V_{DD} - V_{SS}$	-0.3	6.0	V
Supply Voltage(LCD)	$V_{DD} - V_o$	-0.3	19.0	V
Input Voltage	V_i	-0.3	$V_{DD} + 0.3$	V
Operating Temp.	T_{opr}	-20	70	°C
Storage Temp.	T_{stg}	-30	80	°C

MECHANICAL DATA

Item	Nominal Dimensions	Unit
Module Size (W x H x T)	78.0 x 70.0 x 13.0	mm
Viewing Area (W x H)	62.0 x 44.0	mm
Dot Pitch (W x H)	0.44 x 0.60	mm
Dot Size (W x H)	0.40 x 0.56	mm
Weight	Approx. 70	g

ELECTRICAL CHARACTERISTICS ($V_{DD}=5V\pm0.5V$)

Item	Symbol	Test Condition	Min.	Typ.	Max.	Unit
Input High Voltage	V_{IH}	--	2.0	--	V_{DD}	V
Input Low Voltage	V_{IL}	--	0	--	0.8	V
Output High Voltage	V_{OH}	$I_{OH} = -0.2mA$	2.4	--	V_{DD}	V
Output Low Voltage	V_{OL}	$I_{OL} = 1.6mA$	0	--	0.4	V
Supply Current	I_{DD}	$V_{DD} = 5.0V$	--	6.0	8.0	mA
LCD Driving Voltage	$V_{DD} - V_o$	$T_a=25^\circ C$	--	11.2	--	V

PIN CONNECTIONS

Pin	Symbol	Level	Function
1	/CS1	L	Chip selection for IC1. Active "L".
2	/CS2	L	Chip selection for IC2. Active "L".
3	V_{SS}	0V	GND
4	V_{DD}	5V	Power supply for logic
5	V_o	--	Operating voltage for LCD
6	RS	H/L	H : Data L : Instruction code
7	R/W	H/L	H : Read L : Write
8	E	H,H \rightarrow L	Enable signal
9	DB0	H/L	Data bus
10	DB1	H/L	
11	DB2	H/L	
12	DB3	H/L	
13	DB4	H/L	
14	DB5	H/L	
15	DB6	H/L	
16	DB7	H/L	
17	/RST	L	Reset signal. Active "L".
18	V_{OUT}	-10V	Output voltage for LCD driving
19	LEDA	5V	Power supply for LED backlight
20	LEDK	0V	

BLOCK DIAGRAM

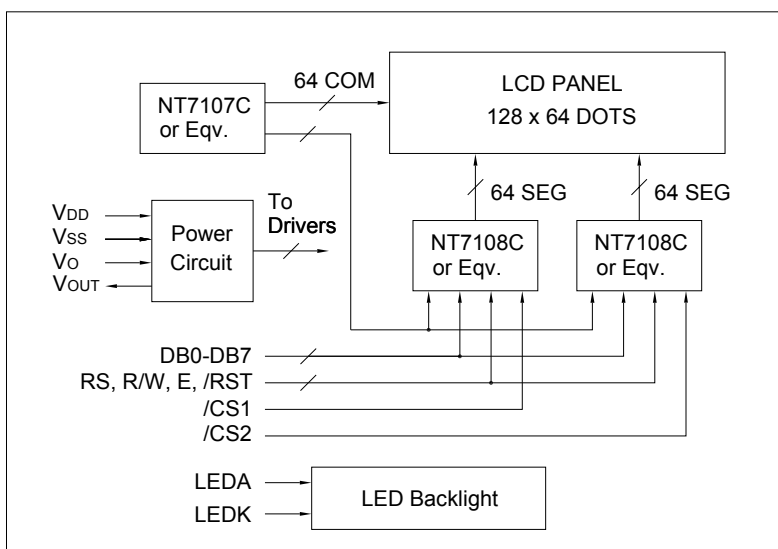

LED BACKLIGHT SPECIFICATIONS ($T_a=25^\circ C$)

Item	Symbol	Typ.	Max.	Unit
Forward Voltage	V_f	3.1	3.3	V
Forward Current	I_f	40	--	mA
LED Color		Yellow Green		